



Consumer Ethical Decision Making: Linking Moral Intensity, Self-Consciousness and Neutralization Techniques

Syed Afzal Moshadi Shah¹ and Shehla Amjad²

Abstract

The purpose of the study is to examine the effect of moral intensity on self-conscious emotions and neutralization techniques in the context of ethical decision making among consumers. A sample of 388 shopping mall retail consumers was recruited through self-administered survey technique. Descriptive statistics, exploratory factor analysis, correlation was carried out in SPSS whereas the measurement model and structural relationships were estimated using AMOS.

Results indicate that *moral intensity* positively influences consumer's *self-consciousness*, *neutralization techniques* and *behavioural intention*. Self-consciousness negatively influence consumer's defence mechanism i.e. neutralization techniques. Neither self-consciousness nor neutralization techniques is found to have an impact on consumers' behavioural intention. Only self-consciousness is found to complementary mediate the relationship of moral intensity and neutralization. The limitations associated with field survey and cross-sectional research design are inevitable. The study offers some relevant practical implications for government, marketing professionals and academia. The study is among the pioneer studies that theoretically links and empirically examines *Issue Contingent Model*, *theory of neutralization* and *self-consciousness*. The study develops and tested an Urdu language version of the questionnaire for retail consumers.

Keywords: Moral Intensity, Self-consciousness, Neutralization Techniques, Behavioural Intention, Consumer Ethics, Decision Making

JEL Classification: M40, G34.

¹ COMSATS Institute of Information Technology, Abbottabad, Pakistan

² COMSATS Institute of Information Technology, Abbottabad, Pakistan

1. INTRODUCTION

The literature on business ethics can be traced back to 1920 however it is recently getting popular among researchers around the world. The initial focus of business ethics studies has remained biased towards examining the role and responsibilities of seller's side and has ignored the buyer's side. It was the work of Muncy & Vitell (1992) that has highlighted the importance of the consumer side in maintaining ethical balance in the businesses (Vitell, 2003). Since then a plethora of studies have focused consumer ethics however the discovery have just revealed the tip of the iceberg. Consumer aberrant behaviour at marketplace is still a bigger challenge to researchers (Caruana, Carrington, & Chatzidakis, 2015; Chatzidakis, Hibbert, & Smith, 2006; Chatzidakis & Mitussis, 2007). Why consumers have behaved differently from their verbal statement or belief has remained the major question to date. Young, Hwang, McDonald, & Oates (2010) have reported only 5% of the 30% consumers registering their concern over environmental issues have confirmed through their behaviours. Caruana et al.(2015) blames the methodological procedures adopted by previous studies that have naively taken consumer behaviour as a rational process. Such studies have largely ignored the bigger picture containing historic, social and cultural dimensions in which consumers exist.

In order to solve this puzzle the study conceptually links and empirically examines three well established theories being used in three different disciplines. First, the issue-contingent theory is a famous rational model by Jones (1991) that emphasizes upon "moral issue intensity" and is developed for organizational settings. Second, the theory of neutralization techniques by Sykes & Matza (1957) is a highly acknowledged theory being used in the field of criminology that explains the rationalization process of a criminal act used by a criminal. Third, a well established scale for measuring non-rational aspect i.e. self-consciousness by Scheier & Carver (1985) is used in the field of self-conscious emotions. The relationship between emotions and their impact on the subsequent behaviour is well established in the literature (Guerra, Huesmann, & Zelli, 1993; Weiner, 1985). Self-consciousness on the other hand has earned little attention among researchers (Tracy & Robins, 2007; Tracy & Robins, 2004). Similarly, the "theory of neutralization" has largely been ignored by researchers in social sciences except the field of criminology (Maruna & Copes, 2005). It is recently the theory has found some grounds in consumer settings that involves ethical decision making (Chatzidakis, 2007; Chatzidakis et al., 2006; Mallin & Serviere-Munoz, 2013; McGregor, 2008; Strutton, Vitell, & Pelton, 1994). The impact of the characteristics of the ethical issue on decision making was first identified by Jones (1991) and were called "moral intensity". An issue of high moral intensity in ethically posed situation will invoke consumer's attention towards self-consciousness and defence mechanism (neutralization technique).

The purpose of the study is to explore the impact of moral intensity on self-consciousness and neutralization techniques. Accordingly, the influence of self-consciousness on individual's neutralization technique is also examined. The study basically has three research objectives:

- i. To investigate the impact of moral intensity on self-consciousness and neutralization techniques.
- ii. To investigate the impact of self-consciousness on consumer's neutralization techniques.
- iii. To investigate the impact of moral intensity, self-conscious emotions and neutralization techniques on individual's behavioural intention.

The study is empirically in nature that comprises of a sample of 388 shopping mall consumers. Data is analyzed through descriptive statistics, correlation, exploratory factor analysis (EFA) through SPSS 17.0 while confirmatory factor analysis CFA and model estimations are done through AMOS 20.

The paper is structured as follow: First, the review of the relevant literature on moral intensity, self-consciousness and neutralization techniques is presented, followed by the development of theoretical framework indicating the relationship between each variable. Second, the development of research hypotheses and explanation of the research methodology is given. Third, a discussion on the results, managerial implications and possible future research in the area is presented.

The study mainly contributes in three dimensions. Firstly, it provides a theoretical foundation for linking rational and non-rational aspects involved in consumer ethical decision making process. Secondly, it provides useful insights into the consumer ethical literature in a collectivist cultural setting which is an under research area. Thirdly, it expands the current literature of consumer ethics in Pakistan.

2. REVIEW OF THE LITERATURE

2.1 Consumer Ethics:

Consumer ethics is defined as “the moral principles and standards that guide the behaviours of individuals as they obtain, use, and dispose of goods and services” (Muncy & Vitell, 1992). The field has earned the attention among researchers after the seminal work of Muncy & Vitell (1992). A review of the literature highlight only 5% efforts were made to examine consumer ethics (Murphy & Laczniak, 1981). The field of business ethics has broadly been examined through two types of investigations: normative and descriptive (O’Fallon & Butterfield, 2005). Normative ethics guides on “how individuals should behave” whereas descriptive ethics focuses on “explaining and predicting individual’s actual behaviour” (O’Fallon & Butterfield, 2005, p.375). Similarly, consumer ethics has also been studied from these two dimensions (normative and descriptive) over the period of time. Similar to the concept of “Corporate Social Responsibility - CSR”, researchers like Vitell (2014) have introduced a new concept called “Consumer Social Responsibility – CnSR”. Vitell (2014) has differentiated between “consumer ethics” and “consumer social responsibility. According to him the responsibilities of the

consumers towards stakeholders (involving one to one relationship) comes under the umbrella of “consumer ethics” whereas the responsibilities of the consumers towards society as a whole are termed as “consumer social responsibility”. Schlegelmilch & Magdalena (2010) in their state of the art review have forecasted a bright future for consumer ethics. According to them, this field “still has to catch up” especially from the context of socio-demographic aspects, psychographic variables and ethical consumers.

The field of consume ethics is under studied in Pakistan. Few studies have examined ethics through a more general perspective like investigating employees’ business ethics (Akram & Azad ,2011), comparison of business ethics in Pakistan and other countries (Tabish, 2009), the role of religiosity and culture on consumer buying behaviour (Ilyas, Hussain, & Usman, 2011)and academic dishonesty among students , (Nazir & Aslam, 2010). The study of Cheema et al. (2013) has focused consumer ethics however the research is exploratory in nature and the sample is drawn from two organizations (Al-Fatah and Home plus) operating in Faisalabad. Karacaer, Gohar, Aygün, & Sayin (2009) compared the effect of personal values on ethical decision making between Turkish and Pakistani professionals. Mujtaba & Afza (2011) examined the business ethics perception among public and private sector employees. Nazir & Aslam (2010) have examined the academic dishonesty and the perception of students in Pakistan. The study of Shah & Amjad (2015) has examined moral philosophy, self-consciousness and behavioural intention. In another study of Shah & Amjad (2017), they have examined moral ideology, ethical beliefs and moral intensity in Pakistan. The dearth of literature on consumer ethics in Pakistan also provides a source of motivation to empirically examine this.

2.2 Moral Intensity:

Jones (1991) proposed the famous descriptive ethical decision making model called “Issue-contingent model”. The model is a unique model as it introduced a dimension to ethical decision making models by putting focus on the characteristics of the moral issue referred as “moral intensity”. Moral intensity depends on the nature of the ethical issues faced. It is independent of the moral development of the individual who faces this issue. Jones (1991) has classified moral intensity comprising of six components: magnitude of the consequences, proximity, concentration of the effect, social consensus, probability of effect and temporal immediacy.

- i) *Magnitude of the consequences* is the totality of the harm/ benefits suffered by the victim that are resulted from the ethical decision made.
- ii) *Proximity* refers to the closeness felt by the decision maker with the victim of the ethical decision maker. This closeness may exist because of physical, psychological, social or cultural.
- iii) *Concentration of effect* refers to severity of the moral issues regardless of the numbers of the victims of a moral decision.
- iv) *Social consensus* refers to social acceptance or rejection is expected in result of the decision made in the ethical dilemma.

- v) *Probability of Effect* refers to the chances of occurring an event and the probability of resulting in harmful outcomes. Hence it is a product of two functions a) chances of an occurrence of an event b) probability of resulting in harmful outcomes.
- vi) *Temporal Immediacy* refers to the time differences between the ethical decisions made the potential harm/benefit. A decision that posses shorter length in time posses greater temporal immediacy.

The interest in examining moral intensity has seems to grow over the period of time. Between 1994-2000 only two studies examined moral intensity (Loe, Ferrell, & Mansfield, 2000), which increased to 32 studies between 1996-2003 (O’Fallon & Butterfield, 2005). In 2001-2011 twenty two studies on moral intensity were reported (Craft, 2012) with a focus on Awareness, Judgment and Intention as 5, 12 and 5 studies respectively.

Lincoln & Holmes (2011) reported a significant impact of moral intensity on all the three phases of decision making i.e. moral awareness, judgment and intention. Moral intent is giving priority to moral values over other beliefs whereas moral behaviour is the application of the moral intent (Craft, 2012). In another study by Paolillo & Vitell (2002) only moral intensity is reported to have impact on behavioural intention, whereas job satisfaction organizational commitment, existence of corporate codes, enforcement of codes and organizational size had mixed results. Similarly, Ratnasingam & Ponnu (2008) identified a significant impact of moral intensity, perceive risk and moral judgment on behavioural intention. Singh, Vitell, Al-khatib, & Clark III (2007) reported the mediation effect of moral intensity on moral philosophies and ethical judgement. In another study, the impact of experience, salary and gender (female) is found to impact positively on moral intensity (Singhapakdi, Vitell, & Franke, 1999). In a comparison study between Pakistan and Turkey, Karacaer, Gohar, Aygün, & Sayin (2009) reported the respondents in both studies were not statistically different on moral intensity perspective. Davies & Crane (2003) studies moral intensity in the organizational context and have reported moral intensity crucial in making ethical decision making. In a comparative study on US and Malaysian consumers, Singhapakdi, Rawwas, Marta, & Ahmed (1999) found Malaysian consumers possessing less perceptions towards issues of high moral intensity as compared to their US counterparts. The literature calls for more in-depth empirical investigation of moral intensity (Loe et al., 2000).

2.3 Self-consciousness:

The history on exploring moral self is long and can be traced back to Aristotle (Solomon, 1992). However, between 1970 and 1980 a movement of critical investigation of anthropological and ethnographic writings took place. This movement resulted into “post-modernism” and brought the selfhood concept to main stream literature (Cohen, 2002). The work of Blasi (1983) can be rightfully termed as the pioneered work in the field as it lays down a foundation to several proceeding theories in the selfhood field (Jennings, Mitchell, & Hannah, 2015). Duval & Wicklund (1972) laid the pioneer work in differentiating between self and non-self as subjects of investigation on self-awareness literature. A distinction on self between public and private self

was made by Buss (1980), Carver Scheier (1981) and Fenigstein, Scheier & Buss (1975). Scheier & Carver, (1985) introduced a new dimension to exploring self by adding “social anxiety” as a new dimension to self along with private and public self-consciousness. Their study refines the scale proposed by Fenigstein, Scheier & Buss (1975). Scheier & Carver (1985) explains these aspects as under:

- i) *Private Self-consciousness*: This is an individual’s ability to dedicate attention towards more covert and hidden aspects of the self that are concealed from others’ examination or notice. These include “beliefs, aspiration, values and feeling” (Scheier & Carver, 1985, p.687) than an individual hold it privately and don’t wish to disclose to others.
- ii) *Public Self-consciousness*: This is an individual’s ability to think about her/his aspects of self that are of concern for public display. This includes “ones overt behaviour, mannerism, stylistic quirks, and expressive qualities” (Scheier & Carver, 1985, p.687).
- iii) *Social Anxiety*: This includes individual’s apprehension of her/his actions in the context of how others will judge them.

Self-consciousness (public, private & social anxiety) has been extensively examined over the period of time. The link between private self-consciousness with reliability of self-reporting was found higher as compared to public self-consciousness (Nasby, 1989). A negative and significant relationship is found between individual’s self-reflections and psychological wellbeing, whereas a positive and insignificant relationship is found between internal state awareness and psychological wellbeing (Harrington & Loffredo, 2007). The time spent on public or private self-consciousness is not found to be associated with behaviour (Franzoi & Brewer, 1984). Public SC is found to be higher in social anxious individuals (George & Stopa, 2008). Private SC is found to moderate self-deception and moral self-concept (Lu & Chang, 2011). A Turkish version of the Scheier & Carver (1985) on self-consciousness was developed that validated the factor structure and psychometric properties of the scale (Ruganci, 1995). The literature on self-consciousness calls for more in-depth investigation (Tracy & Robins, 2007) specially in other cultures (Jennings et al., 2014) i.e. collectivism cultures.

2.4 Neutralization Techniques:

Sykes & Matza (1957) introduced a new dimension in understanding the reasons for delinquency among youth by purporting the “Techniques of Neutralization”. According to them the reason for behavioural delinquency is a result of unexplored link between crime and the defence mechanism used by the criminals. These justifications used for defence purpose may not be seen as legal or accepted by the society at large. This rationalization process occurs prior to the actual deviant behaviour and facilitates such behaviours. Sykes & Matza (1957) have identified five different types of rationalization (neutralization) techniques:

- i) *The Denial of responsibility*: The individual refuses to accept the responsibilities of the delinquent behaviour and blames other to be responsible for making him to commit this crime. Such an individual considers himself as a “billiard ball” that has no control of the situation.
- ii) *The Denial of Injury*: The individual refuses to accept that any one resulted from delinquent behaviours has injured or got hurt.
- iii) *The denial of a victim*: It is the neutralization technique through which the individual considers that the action he/she performed was a rightful retaliation or punishment.
- iv) *The condemnation the condemner*: A neutralization technique in which the individual develops a rejection of the rejecters. He may consider the condemners as “hypocrites, deviants in disguise or impelled in personal spite” (Sykes & Matza, 1957, p.668).
- v) *The appeal to higher loyalty*: refers to the neutralization technique in which the individual may scarify the interests of the larger group than smaller group i.e. sibling pair, his gang or for friends.

The theory has long remained confined to the field of criminology and was treated as a theory of Criminology Etiology (Maruna & Copes, 2005). It was used to understand justification mechanism of criminals who committed rap, murder and genocide. According to Hazani (1991) the theory is universal in nature and can be utilized in any situation that results into inconsistency between individual’s beliefs and actions. Recent literature indicates an increase in use of neutralization technique theory in business studies. Like the study of Hinduja (2007) was carried out on business students and has reported four techniques showing positive impact on outcome variable – Denial of Injury, Appeal to Higher Loyalties, Denial of Negative Intent, and Claim of Relative Acceptability. In a study conducted on salesmen by Mallin & Serviere-Munoz (2013) a negatively associated between neutralization techniques and behavioural intention is found also limited support for neutralization technique mediation reported. McGregor (2008) conceptually linked the neutralization techniques with consumption. Gruber & Schlegelmilch (2014) reported consumers using neutralization techniques to reduce their dissonance further they use others as an example for their defence mechanism. Steenhaut & Kenhove (2006) have reported an inverse impact of increase in guilt factor with consumer inclination towards unethical behavioural intention. Rogers & Buffalo (1974) developed a scale for neutralization that accounts for both black and white boys delinquent behaviours. There is a great need to expand the theory of neutralization in the field of consumer ethics regardless cross cultural or not (Vitell, 2003). Researchers like Maruna & Copes (2005) call for linking neutralization techniques with social and structural processes.

2.5 Hypotheses Development:

The importance of moral issue intensity in the ethical decision making process was long ignored until Jones (1991). A plethora of studies have been carried out examining the impact of moral issue intensity with different variables effecting decision making in ethically posed situations. The dimensions of moral intensity are found significant determinant of moral judgement (Leitsch, 2006). The individuals having a higher sense of responsibility when faced an ethical posed situation are expected to invoke a higher level of self-consciousness (Molinsky & Margolis, 2005).

H1: Moral intensity (MI) is positively associated with self-consciousness (SCE)

McGregor (2008) strongly believe that the moral intensity is related to consumer neutralization techniques. According to him the higher the level of moral intensity the greater the individual will feel to use defence mechanism i.e. neutralization techniques. Gruber & Schlegelmilch (2014) calls to link the techniques of neutralization with moral intensity to better understand the discrepancy between intention and behaviour.

H2: Moral intensity (MI) is positively associated with neutralization techniques (NEU)

Individual's ethical attitudes are strongly linked to their ethical intentions (Reidenbach & Robin, 1990). The relationship between the moral intensity and behavioural intention has also been reported positive by certain empirical studies carried out in the field (Karacaer, Gohar, Aygün, & Sayin, 2009, Leitsch, 2006, Molinsky & Margolis, 2005).

H3: Moral intensity (MI) is positively associated with establishing moral intention (EMI)

Individuals experiencing higher level of self-consciousness will try to search for reasonable justification for their un/ethical behaviour. Hence, higher the self-consciousness will generate higher need to neutralization techniques (Molinsky & Margolis, 2005). Strutton et al. (1994) reported consumers justifying their unethical behaviours by using techniques of neutralizations.

H4: Self-consciousness (SCE) is negatively associated with neutralization techniques (NEU)

Individuals who care to avoid harm will generate more sympathetic considerations while making a ethical decision (Molinsky & Margolis, 2005). Such individuals will develop positive intention toward ethical behaviour and negative towards unethical behaviours. The study of Uddin & Gillett (2002) reported a significant impact of self monitors on individual's intention to avoid fraudulent reporting.

H5: Self-consciousness (SCE) is positively associated with establishing moral intention (EMI)

Gruber & Schlegelmilch (2014) reported consumers use neutralization techniques to decrease their dissonance and when asked for their unethical behaviour will cite the examples of others

who committed such behaviours. Neutralization techniques is found negatively associated with individual’s establishing moral intent. (Mallin & Serviere-Munoz, 2013).

H6: Neutralization techniques (NEU) is negatively associated with establishing moral intention (EMI)

In light of the above discussion we have further hypothesized the mediation effects of neutralization techniques and self-consciousness as below:

H7: Self-consciousness mediates the relationship of moral intensity and neutralization techniques (NEU)

H8: Self-consciousness mediates the relationship of moral intensity and establishing moral intention (EMI)

H9: Neutralization Techniques (NEU) mediates the relationship of moral intensity and establishing moral intention (EMI)

Figure 1: Theoretical Framework

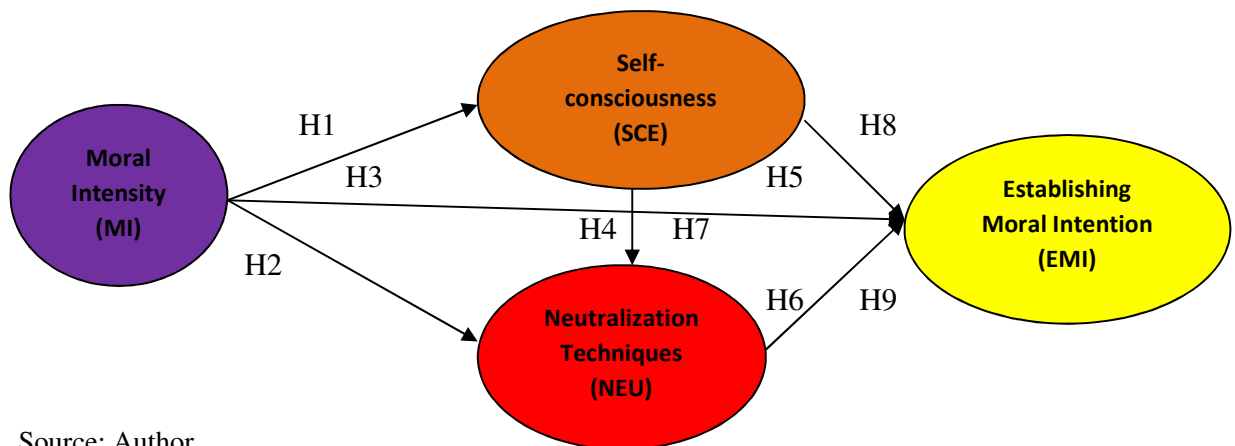

Source: Author

3. METHODOLOGY

This section discusses the methodology adopted by the study to attain research objectives. It explains the sampling technique, data screening process and the variables used and their measurement.

3.1 Sample:

The study employed a convenience sampling procedures. Consumers at major shopping malls in the Hazara region of KPK were intercepted. Following the methodology adopted by Rawwas (2001) every nth number consumer was requested to participant in the survey questionnaire. Each respondent was debriefed about the aims of the research and anonymity of the respondents.

By this method a total of 410 questionnaires were filled in, out of which 22 questionnaire were improperly filled, hence 388 responses were retained for further analysis.

Most of these respondents were young between the ages of 21 to 40 years of age (69%), male (56%), single (47%) and having qualification above Bachelors level (66%). Mostly of them reported living in a joint family system (56%) with an average family size between 5 to 7members of (55%).

3.2 Measures:

The instrument was divided into four sections. Section one contained 5 vignettes adopted from Muncy & Vitell (1992) scale. These vignettes represent consumers behaving unethically in typical shopping/retail settings. All these vignettes are selected from Active/Illegal Dimension of the MV-Scale because of the following reasons:

- a) The active/illegal dimension is empirically found unethical across the globe with majority of the consumers showing less favourable behaviour towards such activities (Vitell, 2003).
- b) All the situations portrayed in these vignettes contain sever unethical/ illegal behaviours that are ideal to elicit respondents concerns towards moral intensity, self-consciousness and neutralization techniques.

Section two contains 5 questions on neutralization techniques through an adopted scale from Strutton et al. (1994). Section three contains 6 questions on moral intensity by adopting the scale used by Paolillo & Vitell (2002) & Singh et al. (2007). The last section contains 22 questions on self-consciousness by adopting the scale proposed by Scheier & Carver (1985).

The responses were recorded on 7 points Likert scale, where 1 indicated “A lot like me” and 7 as “Not at all like me”. Behavioural intention is measured on a 3 points, with ‘1=I will do the same’, “2=Not decided” & “3=I will not do the same”.

3.3 Data analysis techniques

Descriptive statistics, correlation and exploratory factor analysis is carried out through SPSS Version 12, whereas Confirmatory Factor Analysis and Model estimation is done through AMOS 20. Mediation analysis was conducted trough SEM technique (i.e. AMOS). This study examined the mediation through three techniques: Baron & Kenny, Bootstrapping (AMOS) and Zhao decision tree. There are two schools of thought on using Baron & Kenny (1986) technique. The first camp encourages using Baron & Kenny (1986) through SEM techniques in order to reap out reliable results (Baron & Kenny, 1986;Frazier, Tix, & Barron, 2004). The second camp strongly discourages using this approach due to various inbuilt flaws (Hayes, 2009; Zhao, Lynch Jr., & Chen, 2010). Hayes (2009) recommends using bootstrapping technique, whereas Zhao et al. (2010) provides a decision tree to reach a right conclusion (figure-2). Zhao et al. (2010) have shown certain reservation on Baron & Kenny (1986) approach which according to them is either

pushing the researchers to bequeath their research projects or reporting of “partial mediation” . According to them the mediation relationship is beyond the three states of mediation i.e. “full mediation”, “partial mediation” or “no mediation”. They introduced five dimensions of mediation:

1. *Complementary mediation* is a type of mediation in which both mediated effects ($a*b$) and direct effect (c) exist and share the same direction (sign).
2. *Competitive mediation* is a type of meditation in which both indirect ($a*b$) and direct effect (c) exists, however are in different directions.
3. *Indirect-only mediation* is a type of mediation in which only indirect effect ($a*b$) exists, however the direct effect (c) is missing.
4. *Direct-only non-mediation* is a type of mediation in which only the direct effect (c) exists, however the indirect effect ($a*b$) is missing.
5. *No-effect nonmediation* is a type of mediation state where neither indirect nor direct effects exists.

3.4 Translation of the instrument:

The English version of the questionnaire was translated into Urdu with the help of experts using a back-translation and decentering method proposed by Brislin (1986) and followed by Rawwas, Swaidan, & Oyman (2005). A team of 5 experts was used for translation purposes that included two English language experts, two business studies experts and one expert in Psychology. In step one the experts translated the questionnaire into Urdu language. In step two, they share their outcomes with each others and in step three they developed their modified version of Urdu language. In last step they translated back to the English language and they decided upon an acceptance of the final version of the instrument.

3.5 Procedural approaches to reduce “Common Method Biased”

Common method biased is a potential problem to most of the studies involving behavioural research especially with cross sectional research design.

Figure-2: Decision Tree for Establishing and Understanding Types of Mediation and Non-Mediation

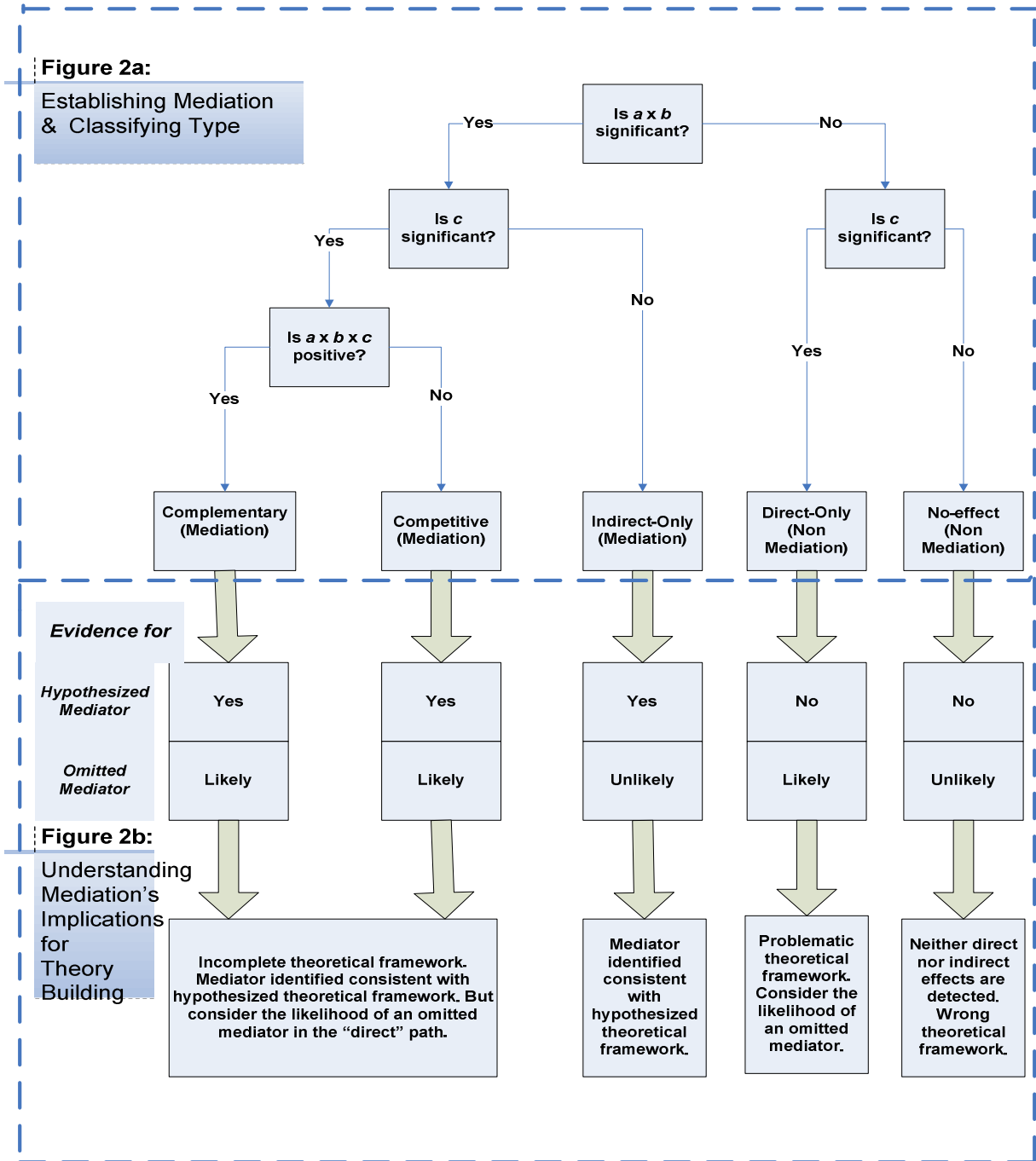

Source: Zhao et al. (2010, p.201)

Following the procedural remedies suggested by Podsakoff, MacKenzie, Lee, & Podsakoff (2003) the study has minimized the possibilities of common method variance. Few of the procedural remedies that the study has followed are given below:

- Social desirability biased: Consumer were ensured about the anonymity of their responses. They were provided time and space to fill in the questionnaire. They were asked to put their questionnaire in a box where other filled in questionnaire were collected. This was carried out to make them comfortable that no one can recall their names or affiliate anything to them.
- Time and Location of Measurement: The data was gathered in the evening. Keeping in view the convenience and comfort of the consumers this timing was preferred.
- Temporal, proximal, psychological, or methodological separation of measurement: Following the direction of Podsakoff, MacKenzie, Lee, & Podsakoff (2003) this was achieved by introducing a time lag between questions. A special care was made in the cover story towards giving a notion that predictor variable measures are separated from criterion variable measures.
- Protecting respondent anonymity and reducing evaluation apprehension: This was achieved through ensured respondents about their anonymity. Respondents were encouraged to freely express their opinion as there was no true and false answer.
- Obtain measures of the predictor and criterion variables from different sources: The study due to its research objectives was deemed to use same sources for data on predictor and criterion variables. Podsakoff et al. (2003) have allowed using the same source where it is inevitable. They have also highlighted several issues related to gathering data from different sources, which in our case would have polluted the whole results.
- Improving Scale items: A special care has been imparted to improve the scale items. Since the questionnaire was adopted from a Western context this step was a crucial one. The study has capitalized upon the comments of the experts in order to achieve content and context validity. The wordings of the questionnaire were improved, localized and buttressed with relevant local examples. For example, in the first question of the annexure A1- the wording “price tags” was supported with a hint of “stickers” which is a commonly used word in the country. Similarly, the word “merchandise” is followed by a hint “shoes”. The word “retail store” is followed by an example of locally famous retail store called “BATA store”. Similarly, in question 2 of annexure#2 the word “soda” is given a hint of “Pepsi or Coke” which are more commonly used words instead of soda. In the same question the word “supermarket” is replaced with shops, keeping view the scarcity of supermarkets in the country and the common usage of the word “shop”. “Changing price tags” is a rare option in the country as most of the shops in the country have salesmen to sell the products. Hence it was replaced with “misleading price information” to shopkeeper. These are few of the examples in which efforts are highlighted in defining ambiguous or unfamiliar terms, avoiding vague concepts and keeping questions simple.

- *Statistical Techniques:* The study has used Harman’s single factor test and has found an absence of single factor accounting for majority of the covariance among measures. Harman’s single factor produced a variance of 34.231% which is well below the recommended variance (table-1). Hence we can conclude that statistically our instrument lacks common method variance (CMV) issue.

Table 1: Harman’s Single Factor Test

Component	Total Variance Explained					
	Initial Eigenvalues			Extraction Sums of Squared Loadings		
	Total	% of Variance	Cumulative %	Total	% of Variance	Cumulative %
1	3.765	34.231	34.231	3.765	34.231	34.231
2	2.245	20.413	54.645			
3	1.447	13.150	67.795			
4	.776	7.055	74.849			
5	.580	5.273	80.122			
6	.461	4.189	84.312			
7	.403	3.666	87.978			
8	.371	3.373	91.351			
9	.336	3.051	94.401			
10	.318	2.894	97.295			
11	.298	2.705	100.000			

Extraction Method: Principal Component Analysis.

Source: Author

2 RESEARCH FINDINGS

4.1 Descriptive Statistics

Descriptive statistics of the direct measures of Neutralization technique (NT), Moral Intensity (MO), Private Self-consciousness (S_P), Public Self-consciousness (S_PR), Social Anxiety and Behavioural Intention (prior to any modifications) are presented in table 2. The results indicate that a majority of the respondents showed less acceptance on Neutralization techniques (mean=4.06, sd=1.47) and moral intensity (mean=5.27, sd=1.37). However the respondents showed strong acceptance of Private Self-consciousness (mean= 2.72, sd=1.24) and Public Self-consciousness (mean= 2.74, sd=1.34) and slight acceptance of social anxiety (mean= 3.70, sd=1.72). On establishing behavioural intention respondents showed slight rejection of unethical behaviour (mean= 2.85, sd=0.417)

Table-2: Descriptive Statistics (N=388)

	Mean	Std. Deviation	1	2	3	4	5	6	7
Neutralization Techniques (NT)	4.0644	1.47974	7	52	89	101	64	50	25
Moral intensity (MO)	5.2732	1.37441	1	15	29	62	84	119	78
Private Self-consciousness (S_P)	2.7242	1.24254	53	142	104	49	30	8	2
Public Self-consciousness (S_PR)	2.7423	1.34321	55	143	107	40	23	13	7
Social Anxiety (S_A)	3.7010	1.72481	39	77	71	68	62	49	22
Behavioural Intention (B)	2.8505	0.41711	9	40	339				

Source: Author

4.2 Dimensionality of the data:

Exploratory Factor Analysis (EFA) is used to examine the relationship between the variables (Pallant, 2005, Hyman & Sierra, 2010). The suitability of the items was examined before making it subject to EFA. The correlation among certain variables was well above the required coefficient value of 0.3 (table-3). The value of Kaiser Meyer Olkin (KMO) was 0.791 which is well above the recommended value of 0.6 (Kaiser, 1970, 1974). Similarly, the value of Balett’s test of sphericity also indicated a statistically significant >0.05 (Bartlett, 1954).

Table-3: Pearson’s Correlation Matrix

	1	2	3	4
MORAL	1			
NEUT	.365**	1		
SCE	.216**	-.012	1	
BEHAV	.216**	.037	.030	1

** . Correlation is significant at the 0.01 level (2-tailed)

* . Correlation is significant at the 0.05 level (2-tailed)

Source: Author

Maximum likelihood technique is used which according to Fabrigar, Wegener, MacCallum and Strahan (1999) is an ideal technique for a “wide range of indexes of the goodness of fit of the model permits statistical significance testing of factor loadings and correlations among factors and the computation of confidence intervals.” (p. 277). Promax rotation a famous Oblique rotation technique is performed that provides solutions with correlated component factors which is very essential for social sciences contrary to Varimax rotation (Matsunaga, 2010 and Thurstone, 1947). Coefficients were suppressed to 0.35 as recommended by Hair, Black, Babin, & Anderson (2014)

The results of maximum likelihood identified a total of 56.199% variance explained by 3 components. The output of the Catell’s (1966) screeplot also confirms the retention of three components for further examination because of a clear break after the third component (figure-3). The items with cross loadings were removed and the final results are presented in Table 4.

Figure 3: Scree Plot

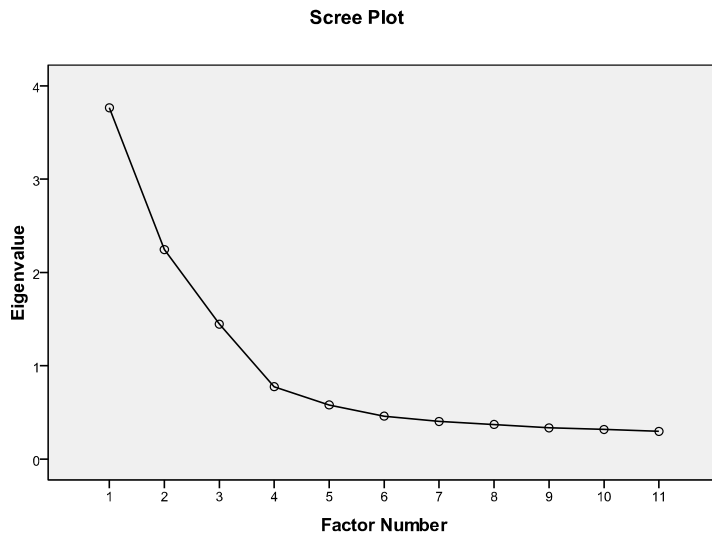

Source: Author

All the items against moral intensity loaded smoothly against factor 1. The items for neutralization technique composed factor 2 however two items due to cross loadings were omitted. These items were for “denial of responsibility” and “appeal to higher loyalties”. The self-consciousness items composed factor 3, where both private self-consciousness and public self-consciousness items were omitted because of poor loadings. This is supported by previous research conducted by Chang (1998), Burnkrant & Page Jr (1984) and Mittal & Balasubramanian (1987).

The Eigen values of the factors are 3.765, 2.245 & 1.447 which is well above the cut score of 1.00 (Costello & Osborne, 2005). The Cronbach Alpha values of 0.839, 0.791 & 0.783 confirm an adequate internal consistency by exceeding the minimum required value of 0.70 (Nunnally, 1978). Validity is ensured through achieving significant loadings 0.714, 0.746 and 0.739 which are all above the required criteria of 0.5 confirming an acceptable convergent validity (Steenkamp & Van Trijp, 1991), whereas the correlation between the threshold level of 0.70 ensures discriminate validity (Ping, 2004).

4.2 Confirmatory Factor Analysis:

A confirmatory factor analysis is carried out to using AMOS v.20. A satisfactory 11 items model was achieved validating the results of EFA. The goodness of fit for CFA achieved acceptable fit with normed chi-square (χ^2/df) =2.298, $df=58$; $p<0.001$. The normed chi-square (χ^2/df) is within the acceptable range of 1-3 as suggested by Carmines and McIver (1981).

Table 4: Pattern Matrix

	Factor		
	1	2	3
There is a very small likelihood that the action will actually cause any harm. (MP)	0.744		
Few people would agree that the action is wrong.(MS)	0.742		
The overall harm (if any) done as a result of the action would be very small (MM)	0.698		
If one were a personal friend of the person(s) harmed, the action would be wrong.(MPR)	0.697		
The action will harm very few people, if any.(MC)	0.692		
Because if the store had more reasonable prices s/he would not have to take such actions. (NV)		0.900	
Because if stores are lax enough to allow people to get away with such behaviour they deserve what they get.(NC)		0.715	
If at the lower price the store still makes a profit.(NI)		0.623	
It hard for me to work when someone is watching me. (SA2)			0.855
It takes me time to overcome my shyness in new situations. (SA1)			0.731
It's hard for me to talk to strangers.(SA3)			0.631
Cronbach's Alpha	0.839	0.791	0.783
Eigen values	3.765	2.245	1.447
Cumulative percent of variation	30.171%	46.736%	56.199%
AVE	0.714	0.746	0.739

Source: Author

However, certain authors like Kline (2011) discourages using this. Other fit indexes RMSEA=0.058 (≤ 0.08), GFI=0.951 (≥ 0.90), CFI=0.958 (≥ 0.95), AGFI=0.927 (≥ 0.90) NFI=0.929 (≥ 0.90), NNFI=0.927 (≥ 0.90), TLI=0.943 (≥ 0.90), RMR=0.180 (close to 0 is good) were within the acceptable ranges recommended by Hu & Bentler (1999) and Kline (2011).

Results also ensured the convergent and discriminate validity of the scales. Figure 4 indicates that the standardized factor loadings of the indicators measuring a certain common factor possess were high (>0.60) ensuring convergent validity. Also the estimated correlations between the factors was lower than recommended value (<0.7).

Figure 4: CFA

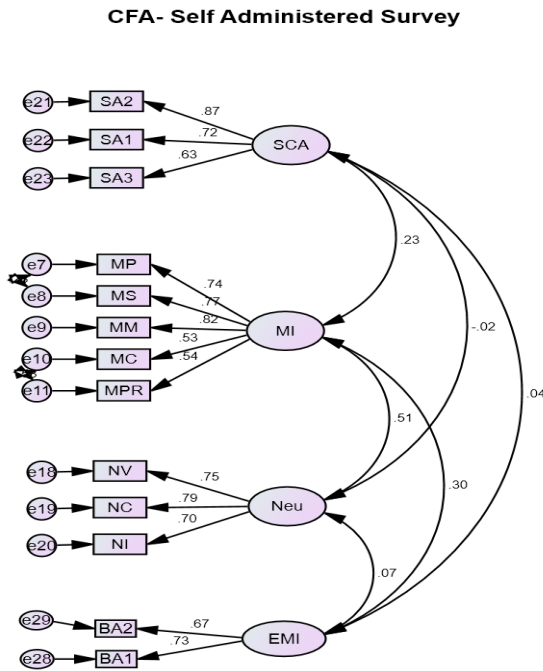

Source: Author

4.3 Structural Model:

The structural model proposed was estimated through AMOSv.20. The analysis yielded a good overall fit $\chi^2(df)=133.277(58)$, $\chi^2/df=2.298(3\leq 1)$; $p<0.001$, RMSEA=0.058 (≤ 0.08), GFI=0.951(≥ 0.90), CFI=0.958 (≥ 0.95), AGFI=0.923(≥ 0.90), NFI=0.929(≥ 0.90), TLI=0.943(≥ 0.90), RMR=0.180 (close to 0 is good).

Figure-5: Structural Model

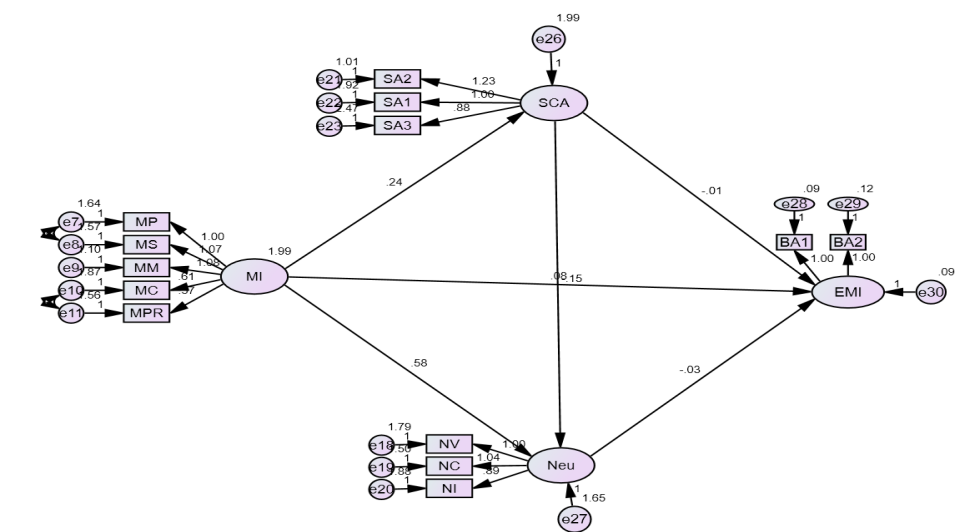

Source: Author

The results (table 5) indicate a significant positive impact of moral intensity on self-consciousness ($B=0.23, p<0.01$). The results confirm the hypothesized relationship in H1. Similarly, moral intensity is also found to be significant positive predictor of neutralization techniques ($B=0.542, p<0.001$), and hence provides enough evidence to accept H2. The relationship of moral intensity and behavioural intention is also found to be significant and positive ($B=0.375, p<0.01$) making us to accept H3. The impact of self-consciousness emotion on neutralization technique as hypothesized in H4 is also found to be significant and negative ($B=-0.143, p<0.05$). Hence we will accept the H4. Both Self-consciousness and neutralization techniques were not found to be associated with moral intention ($B=-0.046, p>0.1$) and ($B=-0.126, p>0.1$) respectively. As the results we haven't received enough support to accept H5 and H6.

Table 5: Standardized Regression weights

Hypot				Standardized	t	Hypothesis
hesis				Coefficient(B)		Supported
H1	Self-consciousness	<--	Moral Intensity	0.230	3.638***	Yes
H2	Neutralization	<--	Moral Intensity	0.542	7.633***	Yes
H3	Intention	<--	Moral Intensity	0.375	4.128***	Yes
H4	Neutralization	<--	Self-consciousness	-0.143	-2.388**	Yes
H5	Intention	<--	Self-consciousness	-0.046	-0.644ns	No
H6	Intention	<--	Neutralization	-0.126	-1.446ns	No

Note: *** $p<0.001$, ** $p<0.05$, ns=not significant

Source: Author

Table 6 presents the results of the mediation analysis in light of the famous Baron & Kenny (1986) approach and bootstrapping. The hypothesized mediation of self-consciousness between moral intensity and neutralization is found significant on all the four paths ($c=.500^{***}$, $a=.214^{***}$, $b=-0.116^{**}$, $c'=0.537^{***}$). Also the significance of the indirect effect using bootstrapping was also found significant at 0.017. However, it does not fulfilled the mandatory conduction of Baron & Kenny (1986) for partial mediation that the indirect effect should be smaller in size as compare to direct effect ($c>c'$). The hypothesized mediated effect (H8) of self-consciousness between moral intensity and neutralization techniques failed at step-3 (path b not found significant) and also the indirect effect was found insignificant using bootstrapping. Similarly, the hypothesized mediation of neutralization techniques between moral intensity and behavioural intention was unable to fulfil the step-3 (i.e. path b not found significant).

Table 6: Mediation Results as per Baron & Kenny (1986)

	Step-1	Step-2	Step-3	Step-4	Significance of Indirect Effect (Bootstrapping)
H7: SCE mediates MI&NEU					
	<i>c=MI on NEU</i>	<i>a=MI on SCE</i>	<i>b=SCE on NEU</i>	<i>c'=MI&SC on NEU</i>	
Values	.500***	0.214***	-0.116**	0.537***	sig**
Condition fulfilled	Yes	Yes	Yes	No	Yes
H8: SCE mediates MI&EMI					
	<i>c=MI on EMI</i>	<i>a=MI on SCE</i>	<i>b=SCE on EMI</i>	<i>c'=MI&SC on EMI</i>	
Values	0.291***	0.214***	-.010(n.s)	0.309***	n.s
Condition fulfilled	Yes	Yes	No	Yes	No
H9: NEU mediates MI&EMI					
	<i>c=MI on EMI</i>	<i>a=MI on NEU</i>	<i>b=NEU on EMI</i>	<i>c'=MI&NEU on EMI</i>	
Values	0.291***	.500***	-.075(n.s)	0.367***	n.s
Condition fulfilled	Yes	Yes	No	Yes	No

Note: *** $p<0.001$, ** $p<0.05$, sig=significant, n.s=not significant, MI=Moral Intensity, SCA=Self-consciousness, NEU=Neutralization Technique, EMI=Establishing Moral Intention
Source: Author

Following Zhao et al. (2010) decision tree framework we found a support for hypothesized relationship H7. Results indicate that self-consciousness mediates the relationship of moral intensity and neutralization and the type of mediation is “Complementary Mediation”. However, no mediation is found for self-consciousness mediating between moral intensity and behavioural

intention (H8) and Neutralization techniques mediating moral intensity and behavioural intention (H9). Both relationships are identified as “Direct-only”. The results of mediation are presented in table 7 and table 8.

Table 7: Mediation analysis using Zhao et al. (2010) method

	H7	H8	H9
Step-1: Is a*b significant	Yes	No	No
Step-2: Is c significant	Yes	Yes	Yes
Step-3: Is a*b*c positive	Yes		
Mediation Type	Complementary Mediation	Direct-only (non-mediation)	Direct-only (non-mediation)

Source: Author

Table 8: Un-standardized Regression Weights

		Estimate	S.E.	C.R.	P
SCA <---	MI	.236	.065	3.638	***
Neu <---	SCA	-.150	.063	-2.388	.017
Neu <---	MI	.581	.076	7.633	***
EMI <---	SCA	-.010	.015	-.644	.520
EMI <---	Neu	-.026	.018	-1.446	.148
EMI <---	MI	.083	.020	4.128	***

Note: MI=Moral Intensity, SCA=Self-consciousness, NEU=Neutralization Technique, EMI=Establishing Moral Intention

Source: Author

3 DISCUSSION and CONCLUSION

The basic purpose of the study was to empirically examine the relationship of moral intensity, self-conscious emotions and neutralization. The study has laid down three measurable research objectives which were achieved through a field survey methodology on retail general consumers in Pakistan.

The results indicate that majority of the respondents are high on all the three aspects of self-consciousness. The respondents showed a high level of sensitivity towards private self-consciousness, followed by public self-consciousness and lastly on social anxiety. The results are in line with the prevailing cultural aspects of the country. According to Hofstede (2010) and Shah and Amjad (2011) there exists a high level collectivist culture in the country. In a particular collectivist culture, individuals of the society give high importance to their norms and values of

the society and also care about the acceptance and rejection from the society. Hence, the findings are supported through the dominant collectivist culture in the county. The respondents have shown little attention towards neutralization techniques and moral intensity. This indicates that the pressure to live up to the acceptable range of social norms and values is higher than the characteristics of the issue or the development of any potential justification towards ethically compromised decision.

The first objective was to examine the impact of moral intensity on self-consciousness, neutralization techniques and behavioural intention was measured through three hypotheses H1 and H2. The results indicate that moral intensity is a significant direct predictor of both self-consciousness and neutralization techniques. In other words, individuals' recognizing the issue sensitivity and its importance will experience a higher level of self-consciousness. These individuals reflect towards their inner feelings before proceeding into issues contain ethical decision making. Consequently their ability to devise rational for their decisions would be higher for incidents possessing a high level of issue sensitivity. The results of the studies are in line with previous studies carried out in the field (Leitsch, 2006; Molinsky & Margolis, 2005; Reidenbach & Robin, 1990; Karacaer, Gohar, Aygün, & Sayin, 2009, Molinsky & Margolis, 2005).

The second objective of the study was regarding the impact of self-consciousness on consumer's neutralization technique was measured through H4. The results reveal that consumers' self-consciousness is negatively affiliated with their ability to justify (neutralization technique) their decision making made under ethical dilemmas. In other words, consumer who found could become aware of self-consciousness deject their inclinations towards development of any renationalization. Such consumer will feel it bad to develop justifications of their decisions under question. The results were found in-line with the hypothesized relationship developed in light of earlier studies in the field (Molinsky & Margolis, 2005; Strutton et al., 1994).

The third objective of the study regarding the impact of moral intensity, self-conscious emotions and neutralization techniques on individual's behavioural intention was examined through H3, H5 and H6. The finding suggests that moral intensity is found significant predictor of making ethical intentions whereas neutralization techniques and self-consciousness were not found related. Hence the hypothesized relationship developed in-light of earlier studies (Molinsky & Margolis, 2005; Uddin & Gillett, 2002; Gruber & Schlegelmilch, 2014; Mallin & Serviere-Munoz, 2013) were not proved. The results indicate the complexity already acknowledge in the literature on intention-behavioural gap. This further indicates inculcating other relevant factors that may influence the establishment of behavioural intention. Self-consciousness was found to complementary mediate the impact of moral intensity on neutralization. Self-consciousness was not found to have any mediation effect on the relationship of moral intensity and behavioural intention. Neutralization techniques were not found to mediate the impact of moral intensity and behavioural intention.

5.1 Practical implications:

The data suggests that the majority of the consumers are high on self-consciousness. They categorized themselves highly sensitive on all three aspects of self-conscious emotions i.e. public, private and social self-consciousness. This aspect of the consumers can serve as an opportunity by carefully devised marketing strategies. While on the other hand if not thoroughly taken care of will serve as a threat to organizations. Being high on private self-consciousness means these consumers wish to keep their covert and hidden aspects of self. For example, in order to promote an ethical behaviour, in particular advertisement consumers can be shown doing a self-reflection when encountered an ethical dilemma in retail settings. The outcome of the consumer self-dialogue situation will be a positive ethical behaviour. Similarly, advertisements depicting ethical situations in which individuals retain their public or social self-consciousness through ethical decisions.

The impact of moral intensity on neutralization techniques, self-consciousness and behavioural intention to avoid an unethical behaviour can also serve an opportunity to companies. Marketing campaign highlighting the importance of issues of moral importance will invoke consumers' sentiments to avoid such incidents during their real life shopping situations.

5.2 Limitations & future research:

The limitations associated with self-administered field survey method are unavoidable. Future studies may consider following an online survey technique or the both. By doing so researchers would be able to improve the quality of the data. The data collection for the study was carried out through convenience sampling technique hence the results can not be generalized to other regions of the country. Future studies may replicate this in different regions of the country in order to get a broaden understanding of the phenomena. The respondents of the study were general retail consumers hence limiting the scope of the findings to retail consumers only. The study can be replicated to other aspects of consumers in health sector, hospitality sector, luxury goods etc. Further, the cross sectional research design has limited the securing of data to 'one response per respondent'. Future studies involving longitudinal research design can get more insights into the ethical decision making process. Similarly, adopting a more qualitative i.e. interviewing can help to understand the real causes of consumer delinquent behaviours.

The effects of cultural diversity on ethical decision making is acknowledged in the literature (Vitell, Nwachukwu, & Barnes, 1993). An existence of sub-cultural effects on provincial level, its impact on managerial decision making and on general consumers of Pakistan is well established in the literature (Shah, 2013; Shah & Amjad, 2011; Zaman, Shah, & Hasnu, 2016). Future studies may put their efforts to examine the differences among different sub-cultures on the basis of their ethical ideologies, beliefs, self-consciousness, sensitivity towards moral intensity, use of neutralization techniques, and decision making. A potential area of study would be to compare and contrast ethical decision making between Pakistan and other countries that

share cultural background i.e. collectivist. Similarly efforts can be carried out to compare these findings with a different cultural backgrounds i.e. individualistic culture.

5.3 Significance of the study

The current study contributes to the literature in three different aspects. Firstly, it extends the literature on consumer ethics by linking moral intensity with self-consciences and neutralization technique. Secondly, the study contributes to the literature on consumer ethics in Pakistan which is in its nascent stages and underexplored. Thirdly, the study contributes towards the methodological aspect by recruiting general consumers which is ignored in most of the previous studies and has used a bi-lingual (English/Urdu) survey questionnaire.

References

- Akram, M., & Azad, M. K. K. (2011). Attitude Towards Business Ethics : Comparison of Public & Private Organizations in Pakistan. *International Journal of Economics and Management Sciences*, 1(3), 73–77.
- Baron, R. M., & Kenny, D. A. (1986). The Moderator-Mediator Variable Distinction in Social Psychological Research: Conceptual, Strategic, and Statistical Considerations. *Journal of Personality and Social Psychology*, 51(6), 1173–1182. <http://doi.org/10.1037/0022-3514.51.6.1173>
- Blasi, A. (1983). Moral cognition and moral action: A theoretical perspective. *Developmental Review*, 3, 178–210. [https://doi.org/10.1016/0273-2297\(83\)90029-1](https://doi.org/10.1016/0273-2297(83)90029-1)
- Burnkrant, R. E., & Page Jr, T. J. (1984). A modification of the Fenigstein, Scheier, and Buss self-consciousness scales. *Journal of Personality Assessment*, 48(6), 629–637. https://doi.org/10.1207/s15327752jpa4806_10
- Caruana, R., Carrington, M. J., & Chatzidakis, A. (2015). Beyond the Attitude-Behaviour Gap: Novel Perspectives in Consumer Ethics: Introduction to the Thematic Symposium. *Journal of Business Ethics*, (JANUARY). <http://doi.org/10.1007/s10551-014-2444-9>
- Chang, L. (1998). Factor Interpretations of the Self- Consciousness Scale. *Person and Individual Differences*, 24(5), 635–640. [https://doi.org/10.1016/S0191-8869\(97\)00222-5](https://doi.org/10.1016/S0191-8869(97)00222-5)
- Chatzidakis, A. (2007). *The role of neutralisation in consumers' ethical decision-making*. University of Nottingham, UK.
- Chatzidakis, A., Hibbert, S., & Smith, A. (2006). “ Ethically Concerned , yet Unethically Behaved ” : Towards an Updated Understanding of Consumer ’ s (Un) ethical Decision Making. *Advances in Consumer Research*, 33, 693–698. Retrieved from <http://www.acrwebsite.org/search/view-conference-proceedings.aspx?Id=12297>
- Chatzidakis, A., & Mitussis, D. (2007). Computer ethics and consumer ethics : The impact of the internet on consumers ’ ethical decision-making process. *Journal of Consumer Behaviour*, 6, 305–320. <http://doi.org/10.1002/cb.223>
- Cheema, K. U. R., Imtiaz, N., & Shafiq, Y. (2013). An Empirical Study of Consumer Ethics : A Comparative Study of Two Firms of Faisalabad , Pakistan. *Journal of Business and Management Sciences*, 1(3), 32–35. <http://doi.org/10.12691/jbms-1-3-1>

- Cohen, A. (2002). *Self Consciousness : An Alternative Anthropology of Identity* (1st ed.). Routledge, Taylor & Francis Group, New York, USA.
- Costello, A. B., & Osborne, J. W. (2005). Best Practices in Exploratory Factor Analysis : Four Recommendations for Getting the Most From Your Analysis. *Practical Assessment, Research & Evaluation, 10*(7), 1–9.
- Craft, J. L. (2012). A Review of the Empirical Ethical Decision-Making Literature: 2004-2011. *Journal of Business Ethics, 117*(2), 221–259. <http://doi.org/10.1007/s10551-012-1518-9>
- Davies, I. A., & Crane, A. (2003). Ethical Decision Making in Fair Trade Companies. *Journal of Business Ethics, 15th Annual Eben Conference, 45*(1), 79–92. Retrieved from <http://www.jstor.org/stable/25075057> <https://doi.org/10.1023/A:1024124629399>
- Duval, S., & Wicklund, R. A. (1972). *A theory of objective self-awareness*. Academic Press, New York.
- Franzoi, S. L., & Brewer, L. C. (1984). The experience of self-awareness and its relation to level of self-consciousness: An experiential sampling study. *Journal of Research in Personality, 18*(4), 522–540. [http://doi.org/10.1016/0092-6566\(84\)90010-2](http://doi.org/10.1016/0092-6566(84)90010-2)
- Frazier, P. A., Tix, A. P., & Barron, K. E. (2004). Testing Moderator and Mediator Effects in Counseling Psychology. *Journal of Counseling Psychology, 51*(1), 115–134. <http://doi.org/10.1037/0022-0167.51.1.115>
- George, L., & Stopa, L. (2008). Private and public self-awareness in social anxiety. *Journal of Behavior Therapy and Experimental Psychiatry, 39*(1), 57–72. <http://doi.org/10.1016/j.jbtep.2006.09.004>
- Gruber, V., & Schlegelmilch, B. B. (2014). How Techniques of Neutralization Legitimize Norm- and Attitude-Inconsistent Consumer Behavior. *Journal of Business Ethics, 121*, 29–45. <http://doi.org/10.1007/s10551-013-1667-5>
- Guerra, N. G., Huesmann, L. R., & Zelli, A. (1993). Attributions for social failure and adolescent aggression. *Aggressive Behavior, 19*(6), 421–434. [https://doi.org/10.1002/1098-2337\(1993\)19:6<421::AID-AB2480190603>3.0.CO;2-N](https://doi.org/10.1002/1098-2337(1993)19:6<421::AID-AB2480190603>3.0.CO;2-N)
- Hair, J. F. J., Black, B. J., Babin, B. J., & Anderson, R. E. (2014). *Multivariate Data Analysis*. Pearson Education Limited, Essex, England.
- Harrington, R., & Loffredo, D. A. (2007). Private Self-consciousness Factors and Psychological Well-being. *Journal of Psychiatry , Psychology and Mental Health, 1*(1), 1–9.
- Hayes, A. F. (2009). Beyond Baron and Kenny: Statistical Mediation Analysis in the New Millennium. *Communication Monographs, 76*(4), 408–420. <http://doi.org/10.1080/03637750903310360>
- Hazani, M. (1991). The universal applicability of the theory of neutralization: German youth coming to terms with the holocaust. *Crime, Law and Social Change, 15*(2), 135–149. <https://doi.org/10.1007/BF00172380>
- Hinduja, S. (2007). Neutralization theory and online software piracy: An empirical analysis. *Ethics and Information Technology, 9*(3), 187–204. <http://doi.org/10.1007/s10676-007-9143-5>
- Hofstede, G. (2010). Cultural Dimensions. Retrieved February 16, 2010, from http://www.geert-hofstede.com/hofstede_dimensions.php
- Hu, L. T., & Bentler, P. M. (1999). Cutoff criteria for fit indexes in covariance structure analysis: Conventional criteria versus new alternatives. *Structural Equation Modeling: A Multidisciplinary Journal, 6*(1), 1–55. <https://doi.org/10.1080/10705519909540118>

- Hyman, M. R., & Sierra, J. J. (2010). *Marketing Research Kit for Dummies*. Wiley Publishing Inc. Hoboken NJ 07030-5774.
- Ilyas, S., Hussain, M. F., & Usman, M. (2011). An Integrative Framework for Consumer Behavior : Evidence from Pakistan. *International Journal of Business and Management*, 6(4), 120–129. <http://doi.org/10.5539/ijbm.v6n4p120>
- Jennings, P. L., Mitchell, M. S., & Hannah, S. T. (2015). The moral self : A review and integration of the literature. *Journal of Organizational Behavior*, 36, 104–168. <http://doi.org/10.1002/job.1919>
- Jones, T. M. (1991). Ethical Decision Making by Individuals in Organizations: An Issue-Contingent Model. *Academy of Management Review*, 16(2), 366–395. <https://doi.org/10.5465/AMR.1991.4278958> <https://doi.org/10.2307/258867>
- Karacaer, S., Gohar, R., Aygün, M., & Sayin, C. (2009). Effects of Personal Values on Auditor’s Ethical Decisions: A Comparison of Pakistani and Turkish Professional Auditors. *Journal of Business Ethics*, 88(1), 53–64. <http://doi.org/10.1007/s10551-009-0102-4>
- Kline, R. B. (2011). *Principles and Practices of Structural Equation Modeling* (3rd ed.). New York: The Guilford Press, London.
- Leitsch, D. L. (2006). Using dimensions of moral intensity to predict ethical decision-making in accounting. *Accounting Education: An International Journal*, 15(2), 135–149. <http://doi.org/10.108/06939280600609151>
- Lincoln, S. H., & Holmes, E. K. (2011). Ethical Decision Making : A Process Influenced by Moral Intensity. *Journal of Healthcare, Science and the Humanities*, 1(1), 55–69.
- Loe, T. W., Ferrell, L., & Mansfield, P. (2000). A Review of Empirical Studies Assessing Ethical Decision Making in Business. *Journal of Business Ethics*, 25, 185–204. <https://doi.org/10.1023/A:1006083612239>
- Lu, H. J., & Chang, L. (2011). The association between self-deception and moral self-concept as functions of self-consciousness. *Personality and Individual Differences*, 51(7), 845–849. <http://doi.org/10.1016/j.paid.2011.07.014>
- Mallin, M. L., & Serviere-Munoz, L. (2013). AN EXPLORATORY STUDY OF THE ROLE OF NEUTRALIZATION ON ETHICAL INTENTIONS AMONG SALESPEOPLE. *Marketing Management Journal*, 23(2), 1–20.
- Maruna, S., & Copes, H. (2005). What We Learned from Five Decades of Neutralization Research ? *Crime and Justice*, 32, 221–320. <https://doi.org/10.1086/655355>
- Matsunaga, M. (2010). How to Factor-Analyze Your Data Right : Do ’ s , Don ’ ts , and How-To ’ s . *International Journal of Psychological Research*, 3(1), 97–110.
- McGregor, S. L. T. (2008). Conceptualizing Immoral and Unethical Consumption Using Neutralization Theory. *Family and Consumer Sciences Research Journal*, 36(3), 261–276. <http://doi.org/10.1177/1077727X07312190>
- Mittal, B., & Balasubramanian, S. K. (1987). Testing the dimensionality of the self-consciousness scales. *Journal of Personality Assessment*, 51(1), 53–68. https://doi.org/10.1207/s15327752jpa5101_5
- Molinsky, A., & Margolis, J. (2005). NECESSARY EVILS AND INTERPERSONAL SENSITIVITY IN ORGANIZATIONS. *Academy of Management Review*, 30(2), 245–268. <https://doi.org/10.5465/AMR.2005.16387884>

- Mujtaba, B. G., & Afza, T. (2011). Business Ethics Perceptions of Public and Private Sector Respondents in Pakistan. *Far East Journal of Psychology and Business*, 3(1), 1–11.
- Muncy, J. A., & Vitell, S. J. (1992). Consumer Ethics: An Investigation of the Ethical Beliefs of the Final Consumer. *Journal of Business Research*, 24(June), 297–311. [https://doi.org/10.1016/0148-2963\(92\)90036-B](https://doi.org/10.1016/0148-2963(92)90036-B)
- Murphy, P. E., & Laczniak, G. R. (1981). Marketing Ethics: A Review with Implications for Managers, Educators and Researchers. *Ben M. Enis and Kenneth J. Roering (Eds.), Review of Marketing 1981 (American Marketing Association, Chicago)*, 251-266.
- Nasby, W. (1989). Private Self-Consciousness, Self-Awareness, and the Reliability of Self-Reports. *Journal of Personality and Social Psychology*, 56(6), 950–957. <https://doi.org/10.1037/0022-3514.56.6.950>
- Nazir, M. S., & Aslam, M. S. (2010). Academic dishonesty and perceptions of Pakistani students. *International Journal of Educational Management*, 24(7), 655–668. <http://doi.org/10.1108/09513541011080020>
- Nunnally, J. C. (1978). *Psychometric Theory*. New York: McGraw-Hill.
- O’Fallon, M. J., & Butterfield, K. D. (2005). A Review of The Empirical Ethical Decision-Making Literature: 1996–2003. *Journal of Business Ethics*, 59(4), 375–413. <http://doi.org/10.1007/s10551-005-2929-7>
- Pallant, J. (2007). *SPSS Survival Manual: A step by step guide to data analysis using SPSS for windows* (3rd ed.). Berkshire UK SL6 2QL: Sydney, McGraw-Hill Education.
- Paolillo, J. G. P., & Vitell, S. J. (2002). An Empirical Investigation of the Influence of Selected Personal , Organizational and Moral Intensity Factors on Ethical Decision Making. *Journal of Business Ethics*, 35, 65–74. <https://doi.org/10.1023/A:1012648521593>
- Ping, R. A. (2004). On assuring valid measures for theoretical models using survey data. *Journal of Business Research*, 57(2), 125–141. [https://doi.org/10.1016/S0148-2963\(01\)00297-1](https://doi.org/10.1016/S0148-2963(01)00297-1)
- Podsakoff, P. M., MacKenzie, S. B., Lee, J.-Y., & Podsakoff, N. P. (2003). Common method biases in behavioral research: a critical review of the literature and recommended remedies. *The Journal of Applied Psychology*, 88(5), 879–903. <http://doi.org/10.1037/0021-9010.88.5.879>
- Ratnasingam, J. K., & Ponnu, C. . (2008). The Influence of Consumers ’ Moral Intensity , Perceived Risks and Moral Judgment in Purchasing Pirated Software. *Communications of the IBIMA*, 1, 47–61.
- Rawwas, M. Y. A. (2001). Culture , personality and morality: A typology of international consumers’ ethical beliefs. *International Marketing Review*, 18(2), 188–209. Retrieved from www.emerald-library.com/ft <https://doi.org/10.1108/02651330110390006>
- Rawwas, M. Y. A., Swaidan, Z., & Oyman, M. (2005). Consumer Ethics : A Cross-Cultural Study of the Ethical Beliefs of Turkish Consumers. *Journal of Business Ethics*, 57(2), 183–195. <http://doi.org/10.1007/s10551-004-5092-7>
- Reidenbach, R. E., & Robin, D. P. (1990). A Partial Testing of the Contingency Framework for Ethical Decision Making: A Path Analytical Approach. *Southern Marketing Association Proceedings*, 121–128.
- Rogers, J. W., & Buffalo, M. D. (1974). Neutralization Techniques: Toward a Simplified Measurement Scale. *The Pacific Sociological Review*, 17(3), 313–331. Retrieved from

- <http://www.jstor.org/stable/1388569> <https://doi.org/10.2307/1388569>
- Ruganci, R. N. (1995). PRIVATE AND PUBLIC SELF-CONSCIOUSNESS SUBSCALES OF THE FENIGSTEIN , SCHEIER AND BUSS SELF-CONSCIOUSNESS SCALE : A TURKISH TRANSLATION. *Personality & Individual Differences*, 18(2), 279–282. [https://doi.org/10.1016/0191-8869\(94\)00149-M](https://doi.org/10.1016/0191-8869(94)00149-M)
- Scheier, M. F., & Carver, C. S. (1985). The Self-consciousness Scale - A Revised Version for use with General Populations. *Journal of Applied Social Psychology*, 15(8), 687–699. <https://doi.org/10.1111/j.1559-1816.1985.tb02268.x>
- Schlegelmilch, B. B., & Magdalena, O. (2010). Half a Century of Marketing Ethics : Shifting Perspectives and Emerging Trends. *Journal of Business Ethics*, 93, 1–19. <http://doi.org/10.1007/s10551-009-0182-1>
- Shah, S. A. M. (2013). Managing Internationalization Strategy with Cultural Realities: Guidelines for Higher Education Institutes in Pakistan. *World Applied Sciences Journal*, 25(11), 1542–1548. <http://doi.org/10.5829/idosi.wasj.2013.25.11.1508>
- Shah, S. A. M., & Amjad, S. (2011). Cultural Diversity in Pakistan : National vs Provincial. *Mediterranean Journal of Social Sciences*, 2(2), 331–344.
- Shah, S. A. M., & Amjad, S. (2015). Examining Moral Philosophy , Self-conscious Emotions and Behavioral Intention among Consumers of Pakistan. *Journal of Business & Economics*, 7(1), 71–102.
- Shah, S. A. M., & Amjad, S. (2017). Investigating moral ideology, ethical beliefs, and moral intensity among consumers of Pakistan. *Asian Journal of Business Ethics*. <http://doi.org/10.1007/s13520-016-0070-6>
- Singh, J. J., Vitell, S. J., Al-khatib, J., & Clark III, I. (2007). The Role of Moral Intensity and Personal Moral Philosophies in the Ethical Decision Making of Marketers: A Cross-Cultural Comparison of China and the United States. *Journal of International Marketing*, 15(2), 86–112. <https://doi.org/10.1509/jimk.15.2.86>
- Singhapakdi, A., Rawwas, M. Y., Marta, J. K., & Ahmed, M. I. (1999). A Cross-Cultural Study of Consumer Perceptions about Marketing Ethics. *Journal of Consumer Marketing*, 16, 257–272. <https://doi.org/10.1108/07363769910271496>
- Singhapakdi, A., Vitell, S. J., & Franke, G. R. (1999). Antecedents, Consequences and Mediating Effects of Perceived Moral Intensity and Personal Moral Philosophies. *Journal of the Academy of Marketing Sciences*, 27(1), 19–36. <https://doi.org/10.1177/0092070399271002>
- Solomon, R. C. (1992). *Ethics and excellence: Cooperation and integrity in business*. NY: Oxford University Press.
- Steenhaut, S., & Kenhove, P. (2006). The Mediating Role of Anticipated Guilt in Consumers' Ethical Decision-Making. *Journal of Business Ethics*, 69(3), 269–288. <http://doi.org/10.1007/s10551-006-9090-9>
- Steenkamp, J. B. E., & Van Trijp, H. C. (1991). The use of LISREL in validating marketing constructs. *International Journal of Research in Marketing*, 8(4), 283–299. [https://doi.org/10.1016/0167-8116\(91\)90027-5](https://doi.org/10.1016/0167-8116(91)90027-5)
- Strutton, D., Vitell, S. J., & Pelton, L. E. (1994). How Consumers May Justify Inappropriate Behavior in Market Settings : An Application on the Techniques of Neutralization. *Journal of Business Research*, 260, 253–260. [https://doi.org/10.1016/0148-2963\(94\)90055-8](https://doi.org/10.1016/0148-2963(94)90055-8)

- Sykes, G. M., & Matza, D. (1957). Techniques of Neutralization: A Theory of Delinquency. *American Sociological Review*, 22(6), 664–670. <https://doi.org/10.2307/2089195>
- Tabish, A. G. (2009). Comparing Standards of Business Ethics in USA , China , Jamaica and Pakistan. *Pakistan Journal of Commerce and Social Sciences*, 3, 49–66.
- Tracy, J. L., & Robins, R. W. (2004). Putting the Self Into Self-Conscious Emotions: A Theoretical Model. *Psychological Inquiry*, 15(2), 103–125. https://doi.org/10.1207/s15327965pli1502_01
https://doi.org/10.1207/s15327965pli1502_03
- Tracy, J. L., & Robins, R. W. (2007). *The Self in Self-Conscious Emotions: A Cognitive Appraisal Approach*. (J. L. Tracy, R. W. Robins, & J. P. Tangney, Eds.) (From The S). The Guilford Press, London.
- Uddin, N., & Gillett, P. R. (2002). The effects of moral reasoning and self-monitoring on CFO intentions to report fraudulently on financial statements. *Journal of Business Ethics*, 40(1), 15–32. <https://doi.org/10.1023/A:1019931524716>
- Vitell, S. J. (2003). Consumer Ethics Research : Review , Synthesis and Suggestions for the Future. *Journal of Business Ethics*, 43(1), 33–47. <http://doi.org/10.1023/A:1022907014295>
- Vitell, S. J. (2014). A Case for Consumer Social Responsibility (CnSR): Including a Selected Review of Consumer Ethics / Social Responsibility. *Journal of Business Ethics, Online*(2012), 1–8. <http://doi.org/10.1007/s10551-014-2110-2>
- Vitell, S. J., Nwachukwu, S. L., & Barnes, H. J. (1993). The effects of culture on ethical decision-making : An application of Hofstede's typology. *Journal of Business Ethics*, 12(10), 753–760. <https://doi.org/10.1007/BF00881307>
- Weiner, B. (1985). An attributional theory of achievement motivation and emotion. *Psychological Review, The American Psychological Association, Inc.*, 92(4), 548–573. <http://doi.org/10.1037/0033-295X.92.4.548>
- Young, W., Hwang, K., McDonald, S., & Oates, C. J. (2010). Sustainable consumption: green consumer behaviour when purchasing products. *Sustainable Development*, 18(1), 20–31.
- Zaman, S., Shah, S. A. M., & Hasnu, S. A. . (2016). Targeting Young Consumers: How Family, Friends and Advertisement Shape Materialism in Pakistan. *Mediterranean Journal of Social Sciences*, 7(4), 703–715. <http://doi.org/10.5901/mjss.2016.v7n4p703>
- Zhao, X., Lynch Jr., J. G., & Chen, Q. (2010). Reconsidering Baron and Kenny: Myths and Truths about Mediation Analysis. *Journal of Consumer Research*, 37(2), 197–206. <http://doi.org/10.1086/651257>

Author notes:

S.A.M Shah is an Assistant Professor in the Department of Management Sciences at COMSATS Institute of Information Technology, Pakistan. He did M.Sc. in Management & HR from Birmingham City University, United Kingdom and an MBA from Quaid-e-Azam University, Islamabad, Pakistan. His research interests during PhD are consumer ethics and decision making. His major research publications are in the field of consumer ethics, cultural diversity in businesses, social media and knowledge management.

Dr. Shehla Amjad is a Professor in the Department of Management Sciences at COMSATS Institute of Information Technology. She did M.A from University of Sussex, UK, an M.A degree from University of Peshawar, PhD from University of Bradford, UK and Post Doc from University of Bradford, UK. She has earned a gold medal in M.A, COT scholarship PhD degree and HEC funding for Post Doc. She is an active researcher who has published more than 40 papers in renowned journals and has participated in numerous research conferences. Her research interests include micro-econometric analysis, rural finance and business ethics.

Both researchers have jointly published six research papers, a book chapter and have earned a research project of funding Pak Rs. 1.61 million from Higher Education Commission of Pakistan.

Annexure 1:
Scenario adopted from Muncy & Vitell (1992)

- You observed a customer changes price tags (stickers) on a merchandise (e.g. shoes) in a retail store (e.g. BATA store)
- You saw a person drinking a can of soda (e.g. Pepsi or Coke) in a supermarket (shop) and left without paying for it.
- You notice a person reported a lost item as “stolen” to an insurance company in order to collect the money.
- You observed a person giving misleading price information to a shopkeeper for an un-priced item.
- A person uses a long-distance access code of (land line) telephone for personal purposes that is given by the company to communicate with Head Office.

Annexure 2:
Neutralization Techniques adopted from Strutton et al. (1994)

1. Denial of responsibility	If s/he felt pressured into such action by forces beyond his/her control.
2. Denial of injury	If at the lower price the store still makes a profit.
3. Denial of victim	Because if the store had more reasonable prices s/he would not have to take such actions.
4. Condemning the condemners	Because if stores are lax enough to allow people to get away with such behaviour they deserve what they get.
5. Appeal to higher loyalties	Because one has to do what they can to improve the lot of their family.

Annexure 3:

Moral intensity adopted from Paolillo & Vitell (2002) & Singh et al., (2007)

1. Magnitude of consequences	The overall harm (if any) done as a result of the action would be very small
2. Social consensus	Few people would agree that the action is wrong.
3. Probability of effect	There is a very small likelihood that the action will actually cause any harm.
4. Temporal immediacy	The action will not cause any harm in the immediate future.
5. Proximity	If one were a personal friend of the person(s) harmed, the action would be wrong.
6. Concentration of effect	The action will harm very few people, if any.

Annexure 4:

Self-Consciousness Measures Adopted from Scheier & Carver (1985)

<p><i>Private Self-consciousness Dimension:</i></p> <ul style="list-style-type: none">• I am constantly thinking about the reasons for doing things• I sometimes step back (in my mind) in order to examine myself from a distance.• I am quick to notice changes in my mood.
<p><i>Public Self-consciousness Dimension:</i></p> <ul style="list-style-type: none">• I care a lot about how I present myself to others• I usually worry about making a good impression.• Before I leave my house I check how I look.• I am concerned about what other people think of me.
<p><i>Social Anxiety Dimension:</i></p> <ul style="list-style-type: none">• It takes me time to overcome my shyness in new situations.• It's hard for me to work when someone is watching me.• It's hard for me to talk to strangers.